

# Outplorer

## Handlebar Clamp Kit

PH10

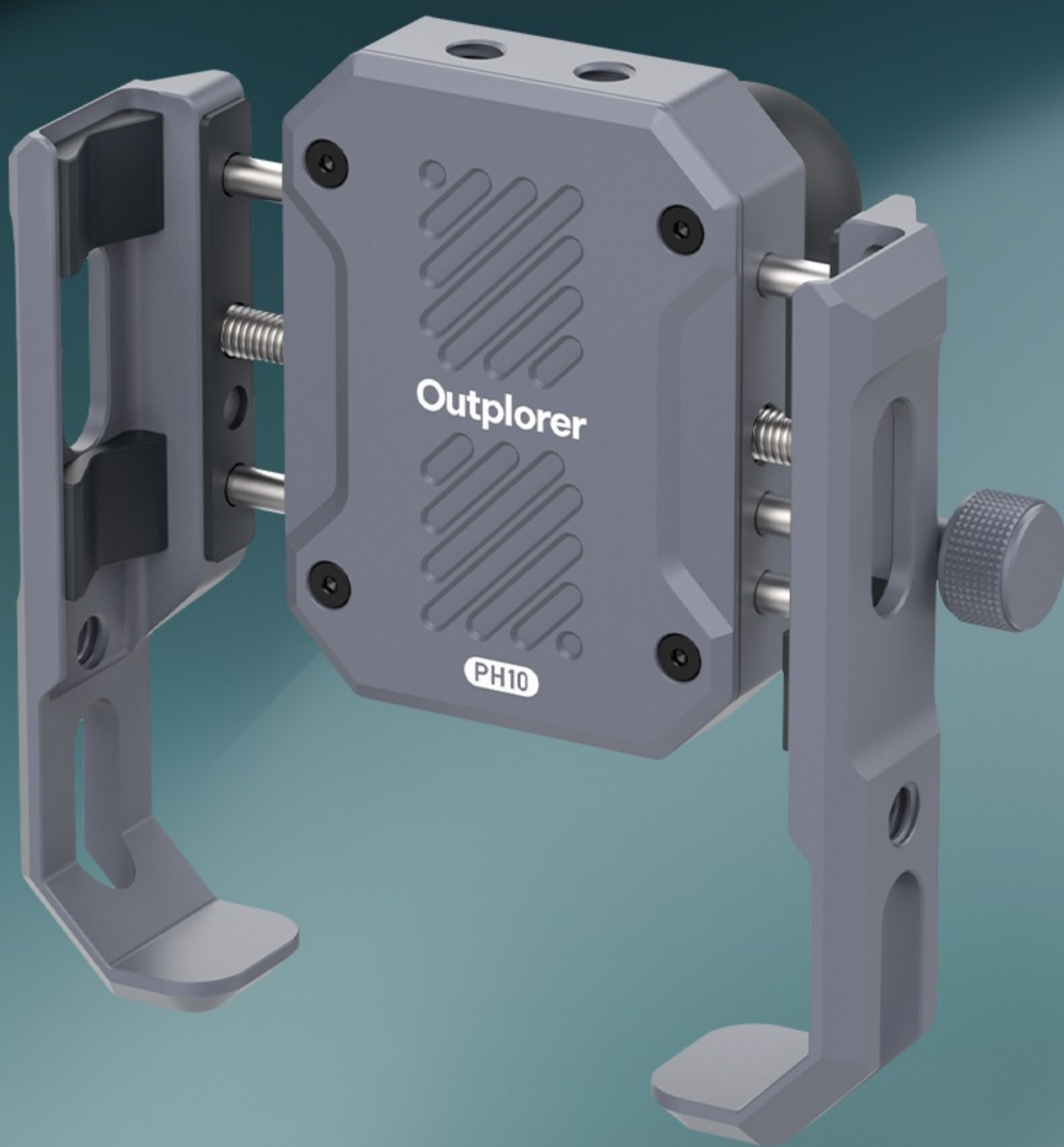

Air  
Suspension



Screen  
Unobstructed

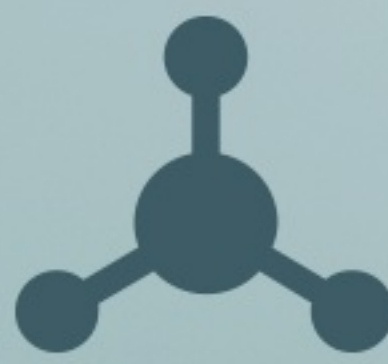

High  
Expandability



Mechanical  
Locking



# Modular Design

The Outplorer air suspension mount series products adopt a **modular design**, where different modules combine to adapt to various scenarios and carriers, offering cycling enthusiasts more freedom for hands-on space and choice of play.

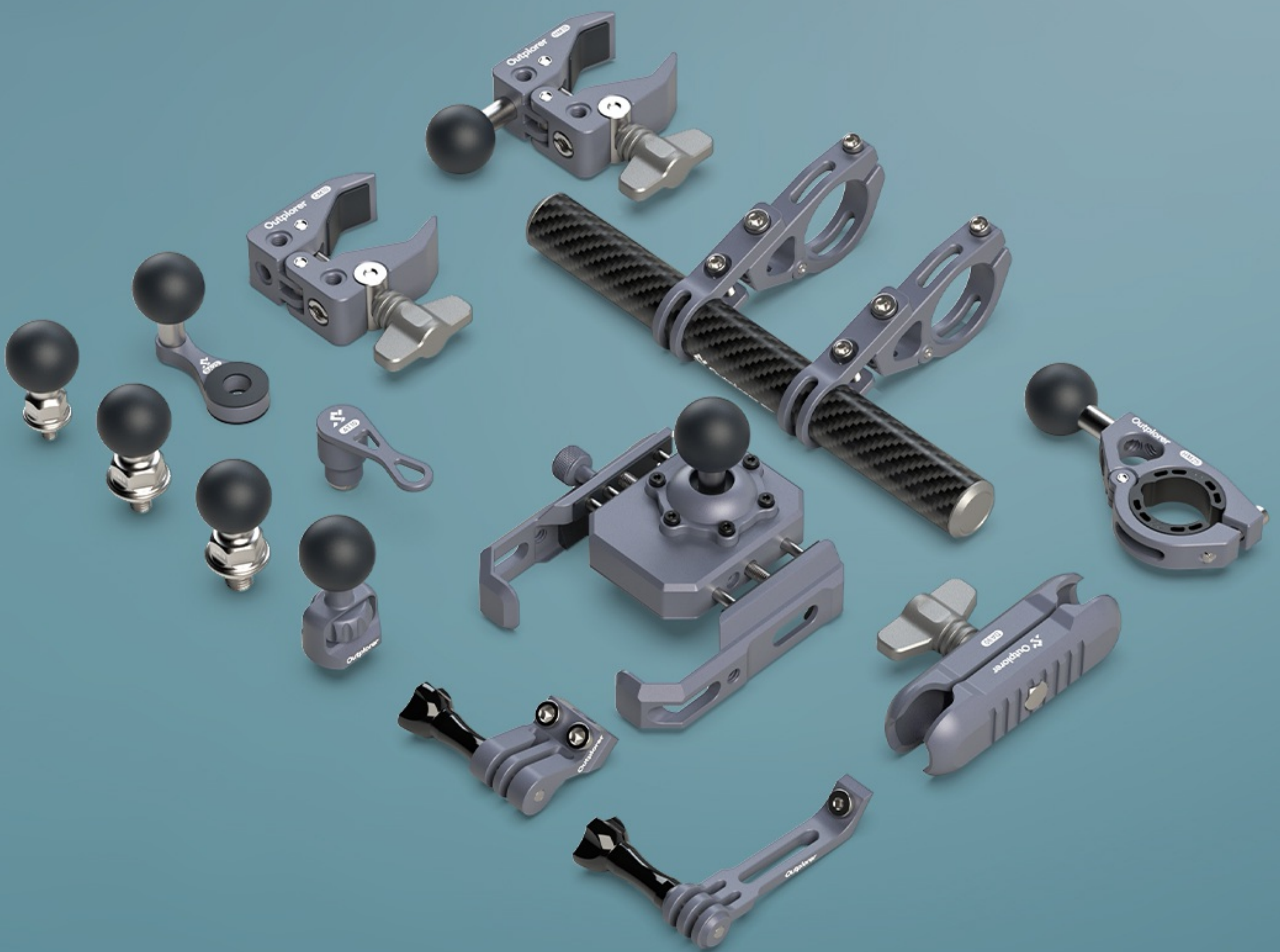







# Air Suspension System

The Outplorer air suspension phone mount breaks through the traditional four-corner shock-absorbing ring design, adopting an innovative patent design of an **airbag suspension**.

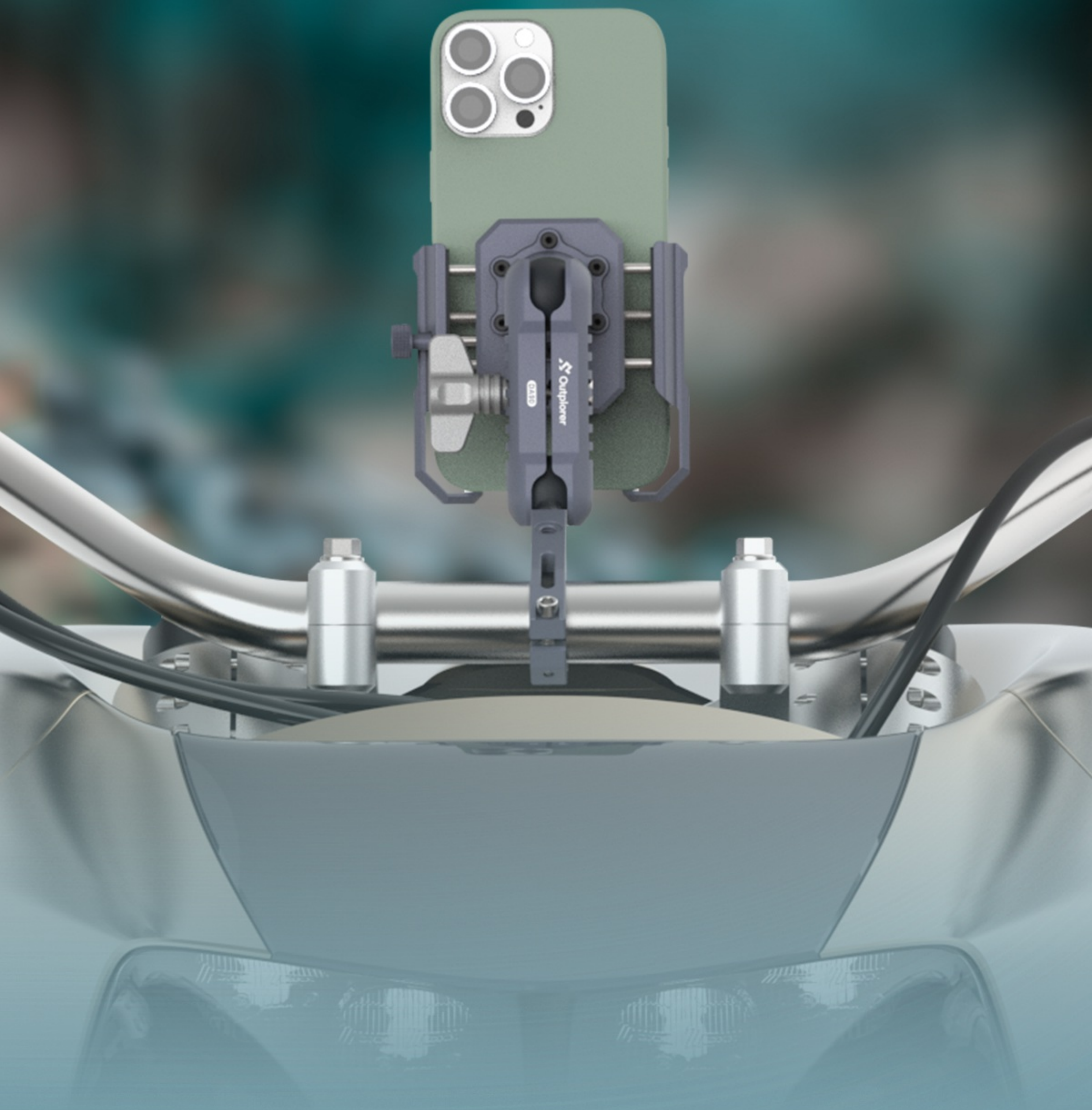

The airbag suspensio design can efficiently filter the high-frequency oscillations generated by the motorcycle cylinder running at high speed, protecting the phone's lens stabilization components from damage.

## Efficiently Filter Various Vibration

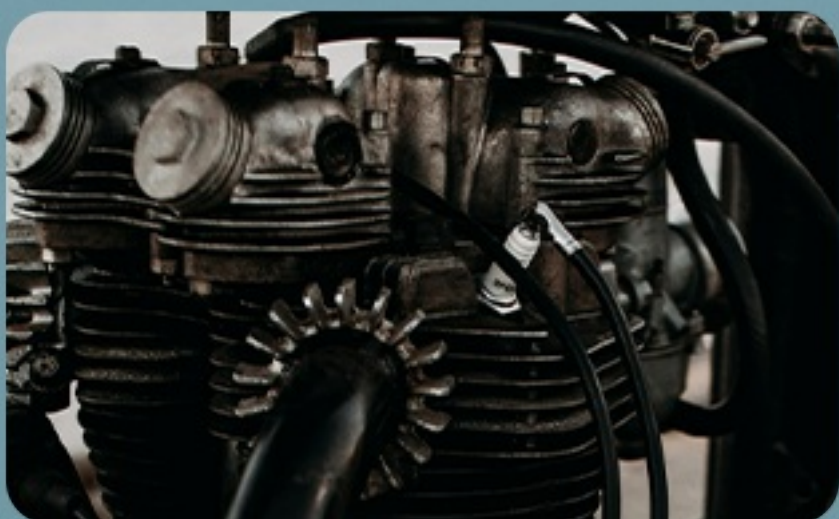

Engine  
Vibration



Deceleration  
Zone

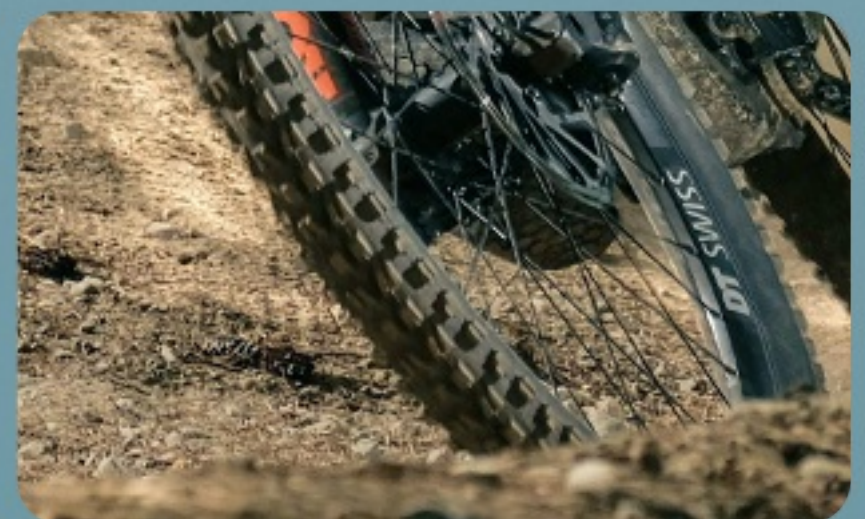

Gravel and  
Sand Road



# The Guardian of Phone OIS

The OIS (Optical Image Stabilization) design of phone cameras ensures that users can take clear shots without blurriness caused by minor shakes.

However, the OIS components can **suffer irreversible damage** if exposed to high-frequency vibrations for extended periods, necessitating the use of a phone mount with superior shock absorption capabilities.

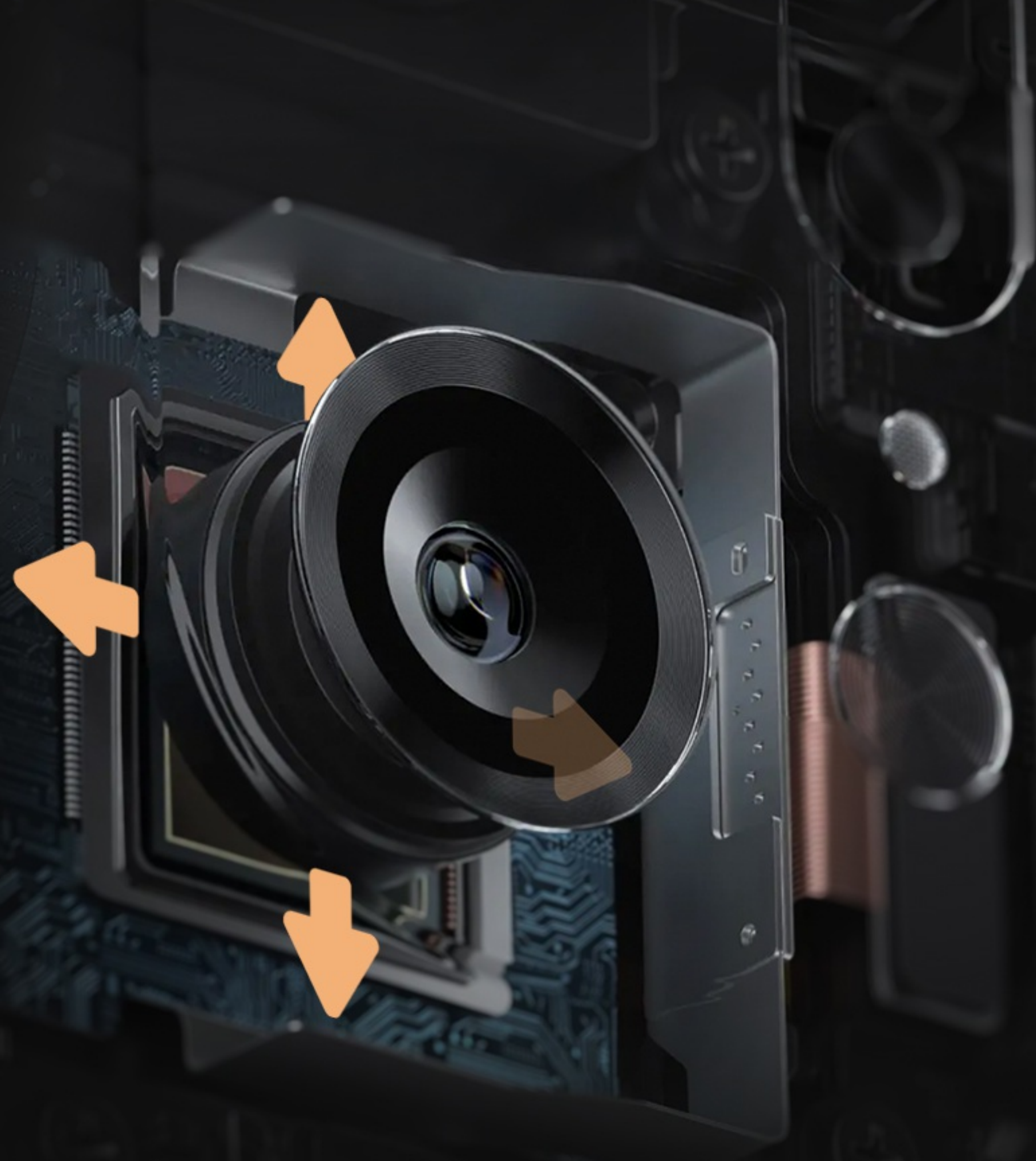

## Original Air Suspension Technology

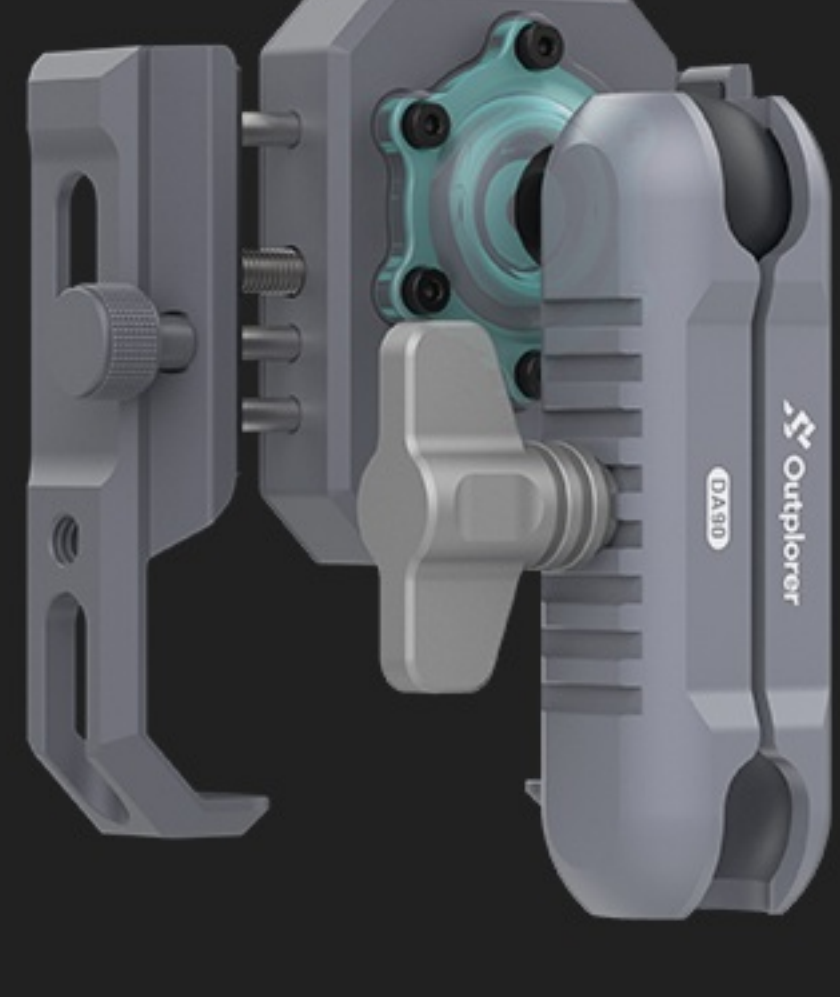

**Air Suspension**

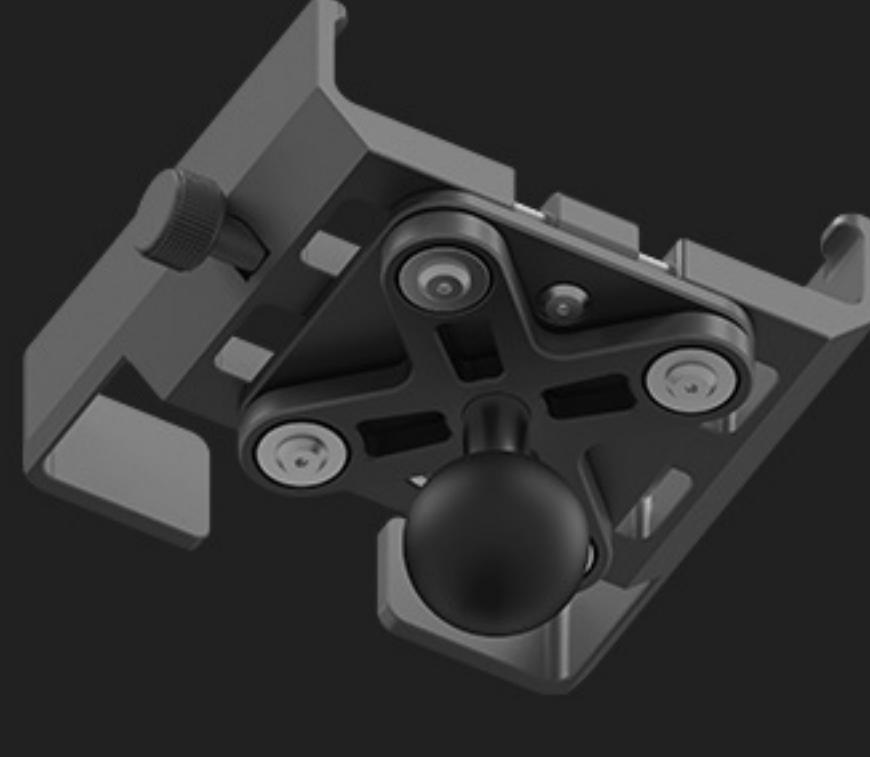

**Traditional Anti Vibration**

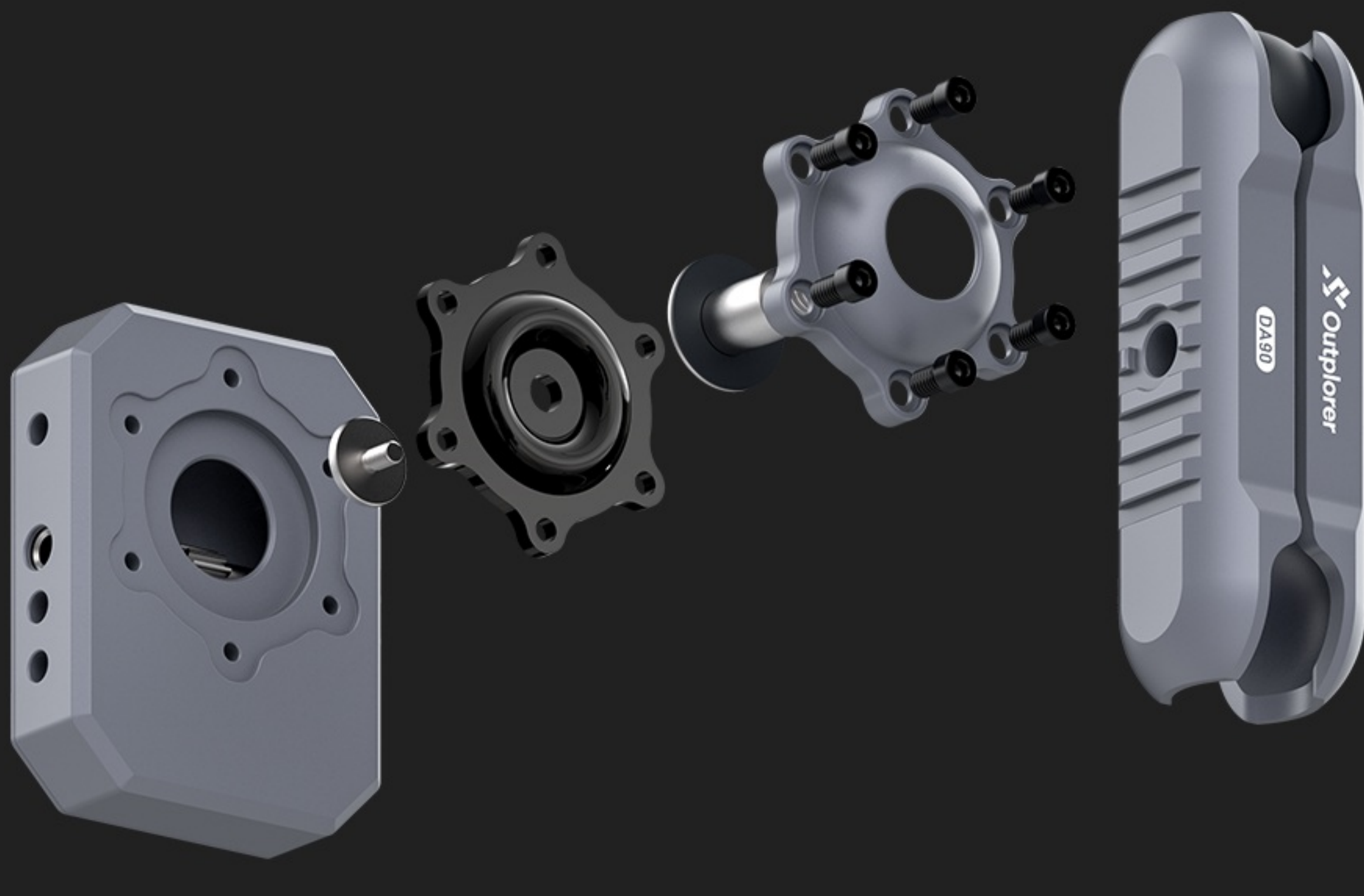

The shock-absorbing airbag design of the Outplorer phone mount is derived from the air springs used in the automotive and aviation sectors.

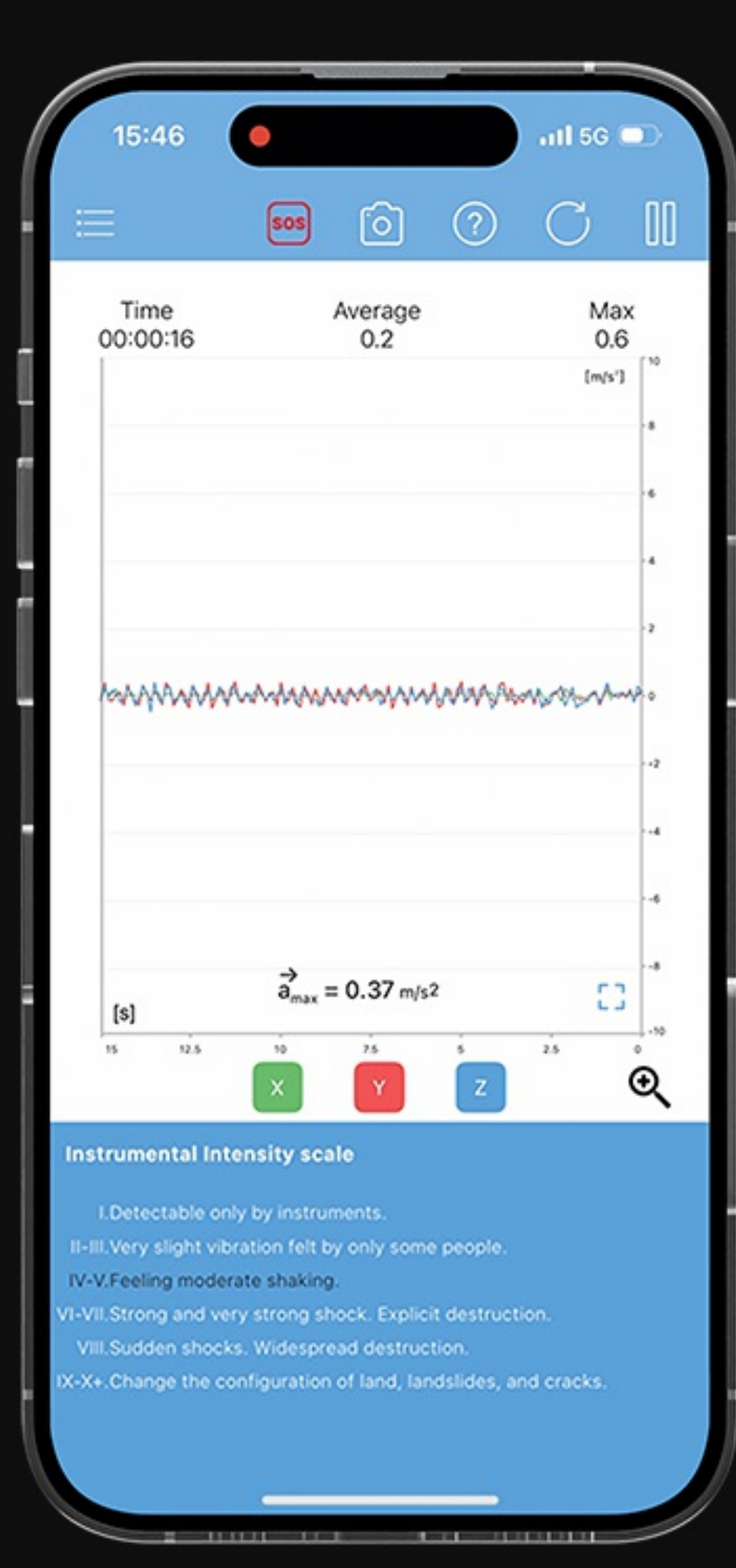

The inflatable airbag can effectively absorb **high-frequency vibrations** and efficiently filter the amplitude on all **three XYZ axes**, properly protecting your phone's lens OIS components.

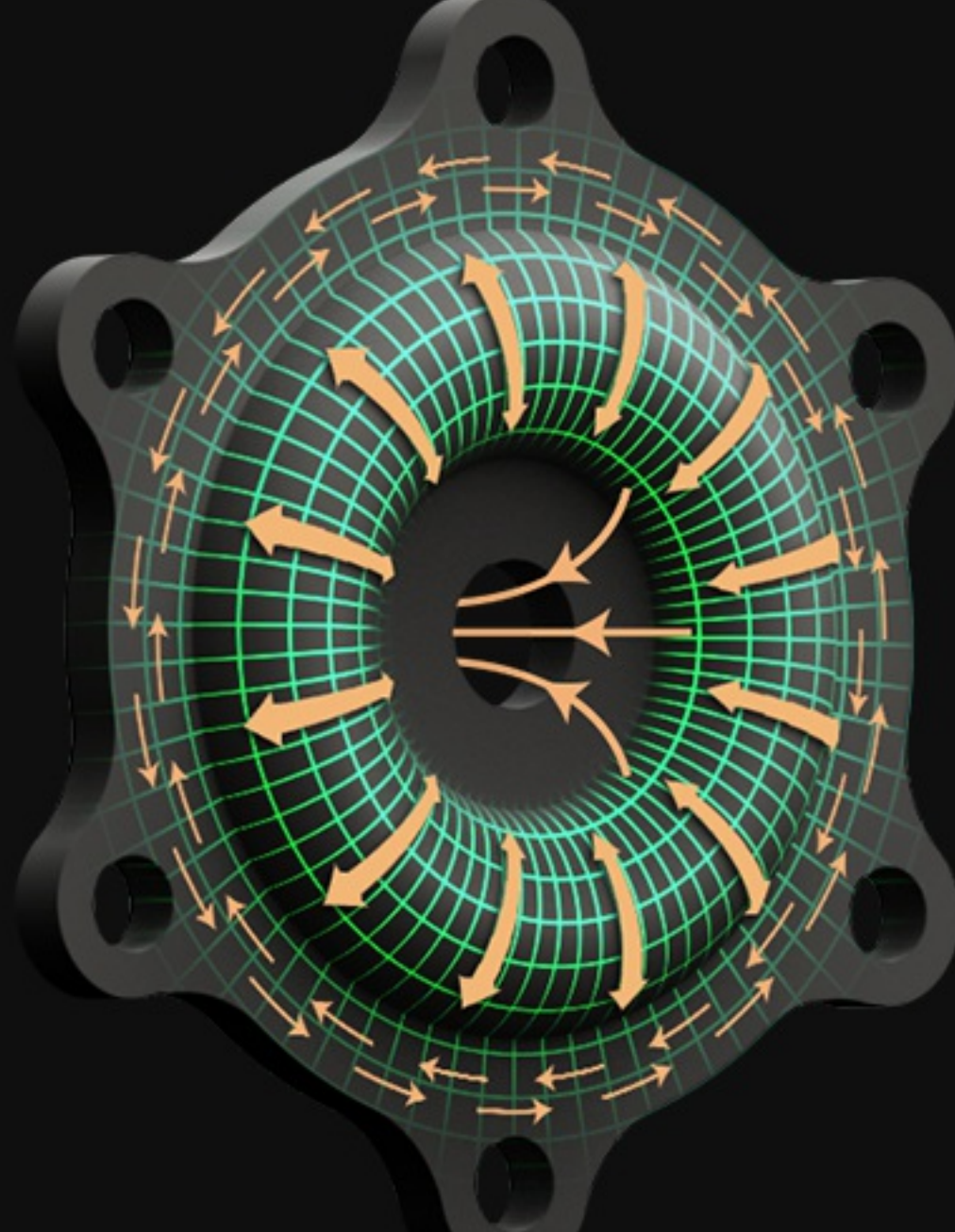



# Ingenious Design Wide Compatibility

## Compatible with All Size Phones

The clamping part of the air suspension phone mount uses a **screw-tightening method** to fix the mobile phone, And can accommodate mobile phones with widths **from 63mm to 97mm**, including the phone cases.

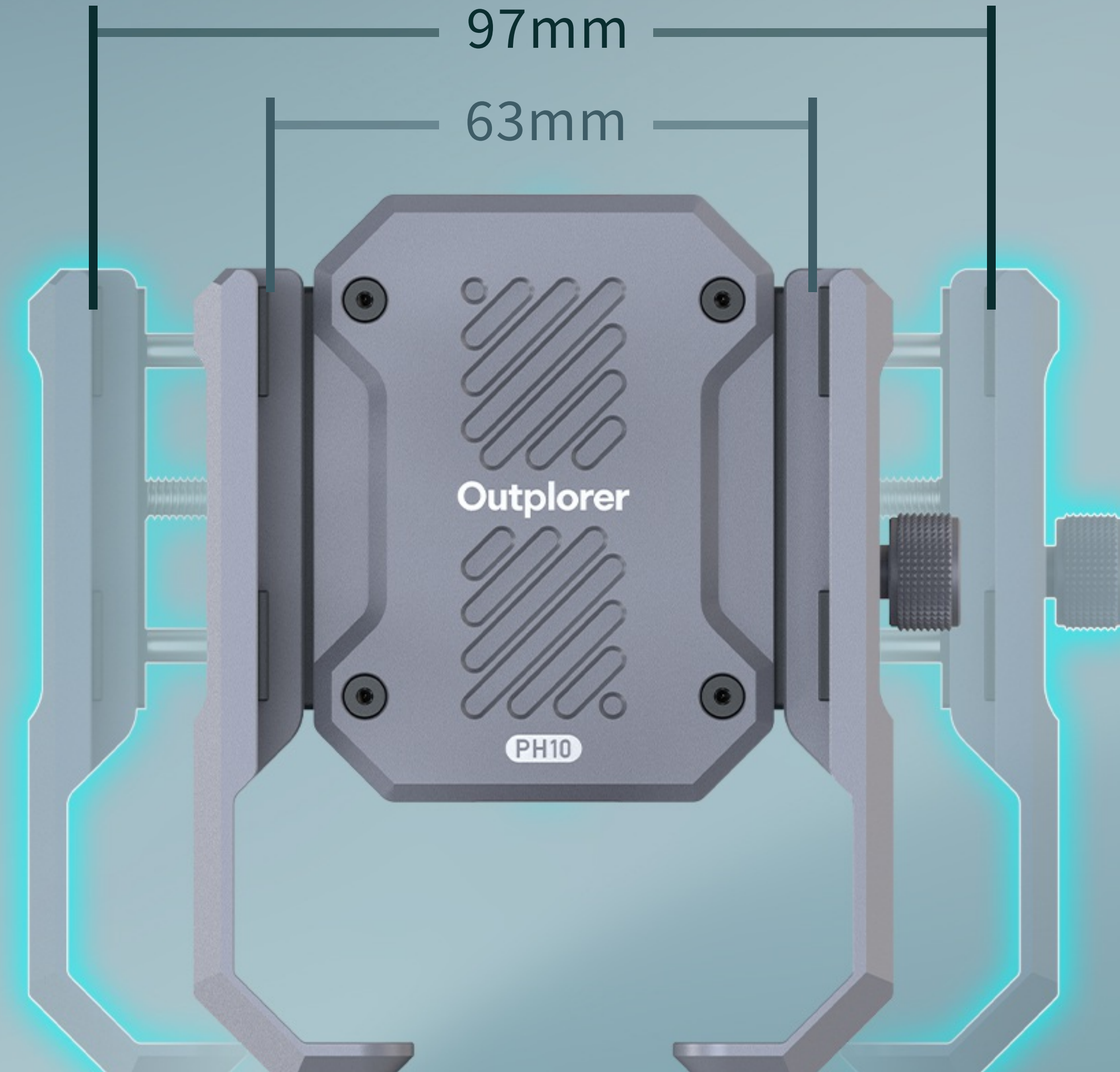

## Telescopic Locking Knob

The knob can be extended and retracted, making it easier for riders with larger hands to operate. The threaded rod tightening design ensures that the phone clamp **will not loosen due to prolonged vibration**, nor will it cause the phone to be thrown out during sudden severe bumps when the vehicle encounters potholes.

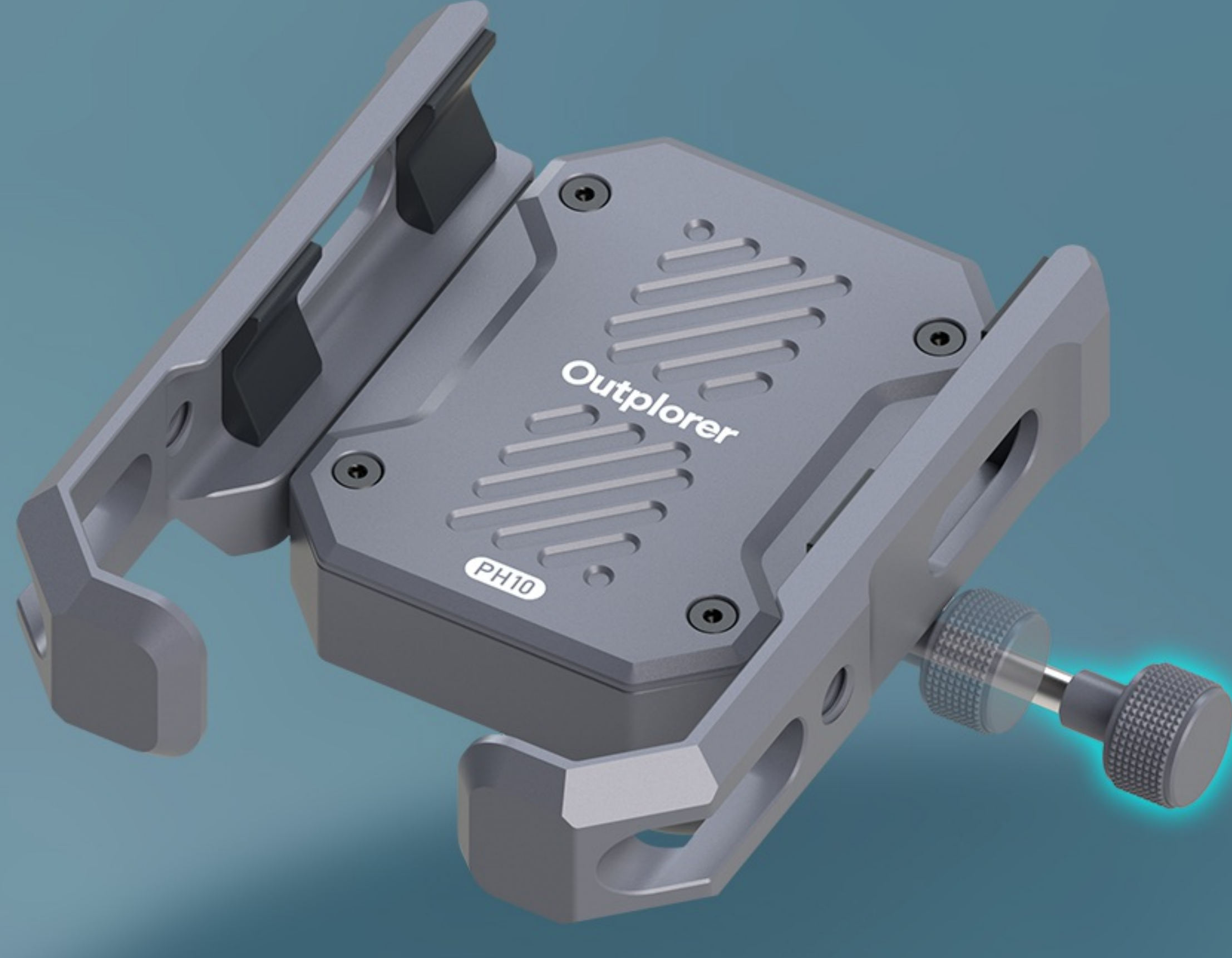

## Gentle on Your Phone

The clamping part can accommodate a maximum thickness of **13mm**, with a certain gap between the bottom of the phone and the base to ensure the phone will not be scratched.

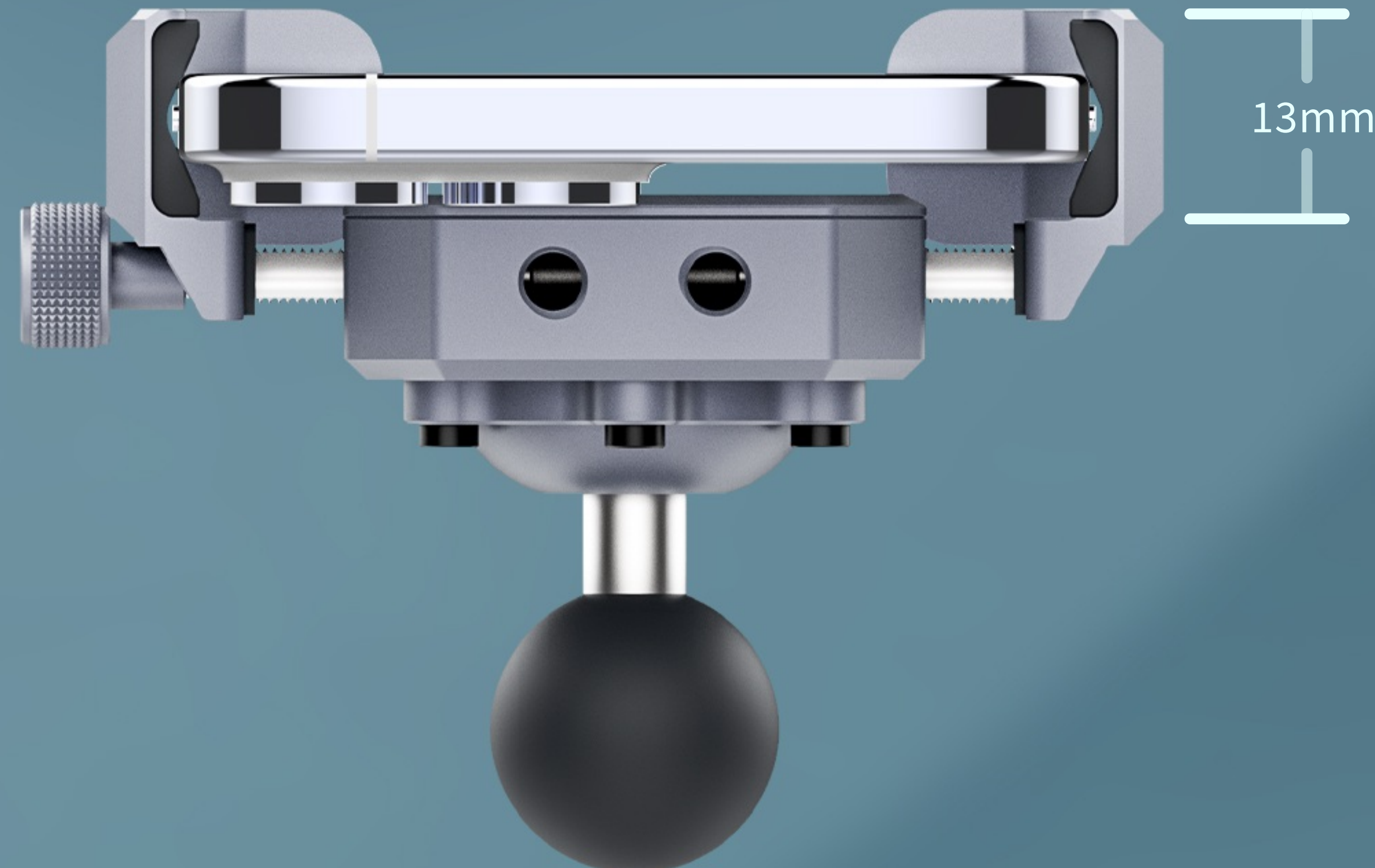

## Powerful Expandability

The Outplorer phone mount features multiple protective pads. Both the phone clamp and the handlebar clamp mount are designed with several standard **1/4 inch screw holes** and a **cold shoe interface**, making it convenient for users to expand or assemble other accessories on their own.

Protective Padding × 4

Standard 1/4 Inches Screw Hole × 4





# Universal Rotation Angle as You Wish

The support rod part of the Outplorer air suspension mount series adopts a universal ball head connecting rod design.

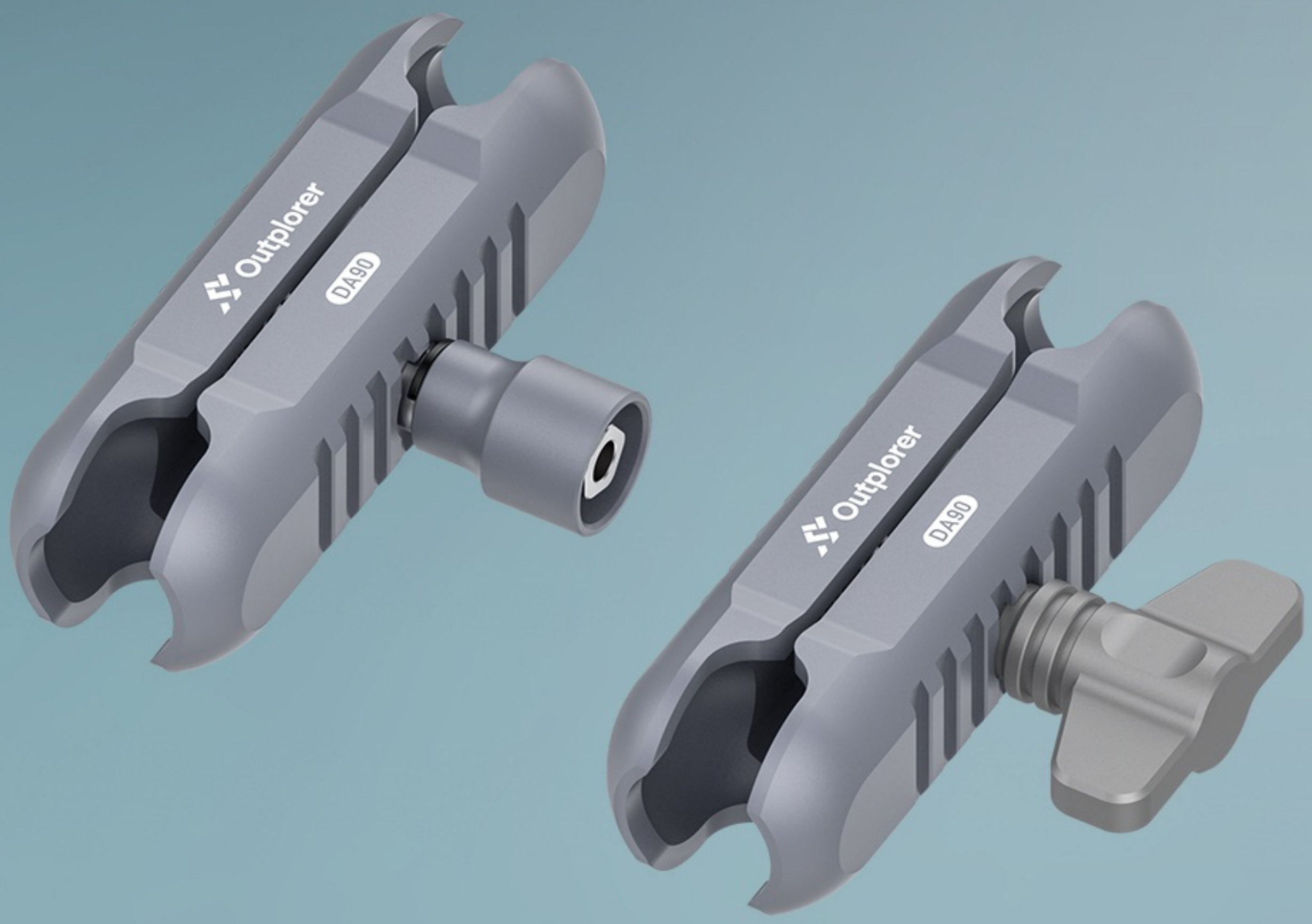

It allows the rider to **freely adjust** the installation angle of the equipment, and can adapt to different equipment and installation environments by replacing the corresponding **ball head accessories**.

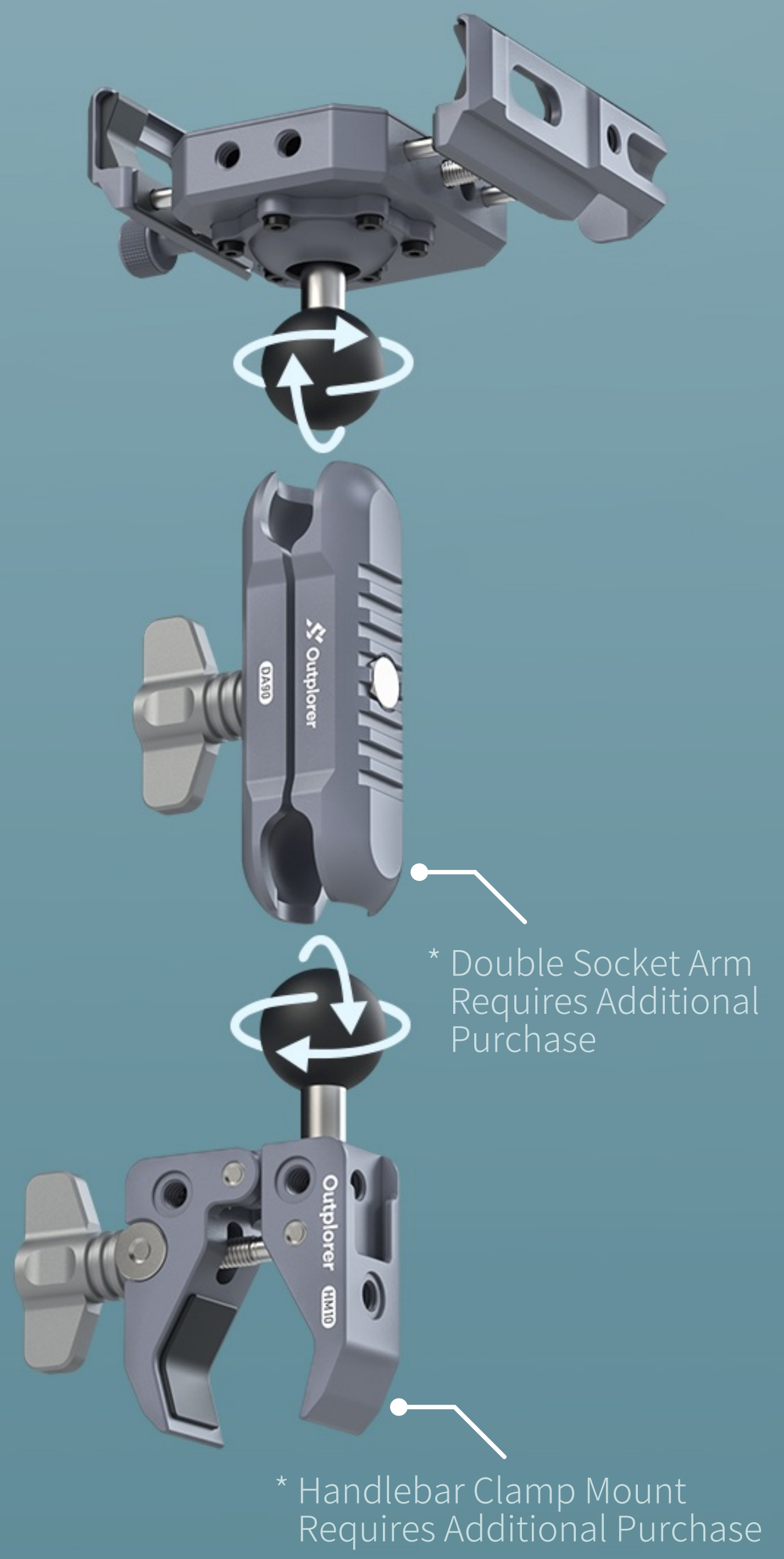
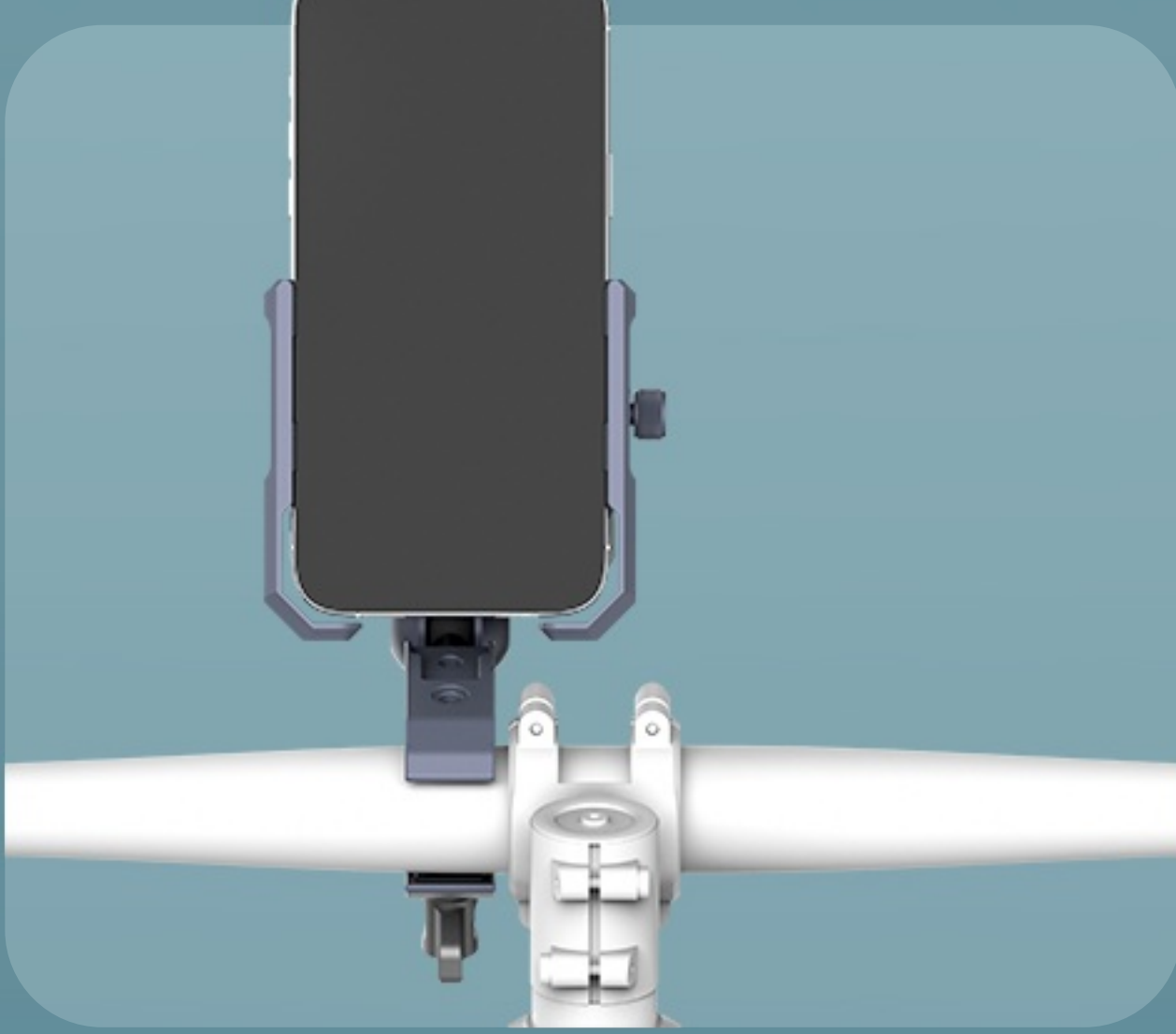
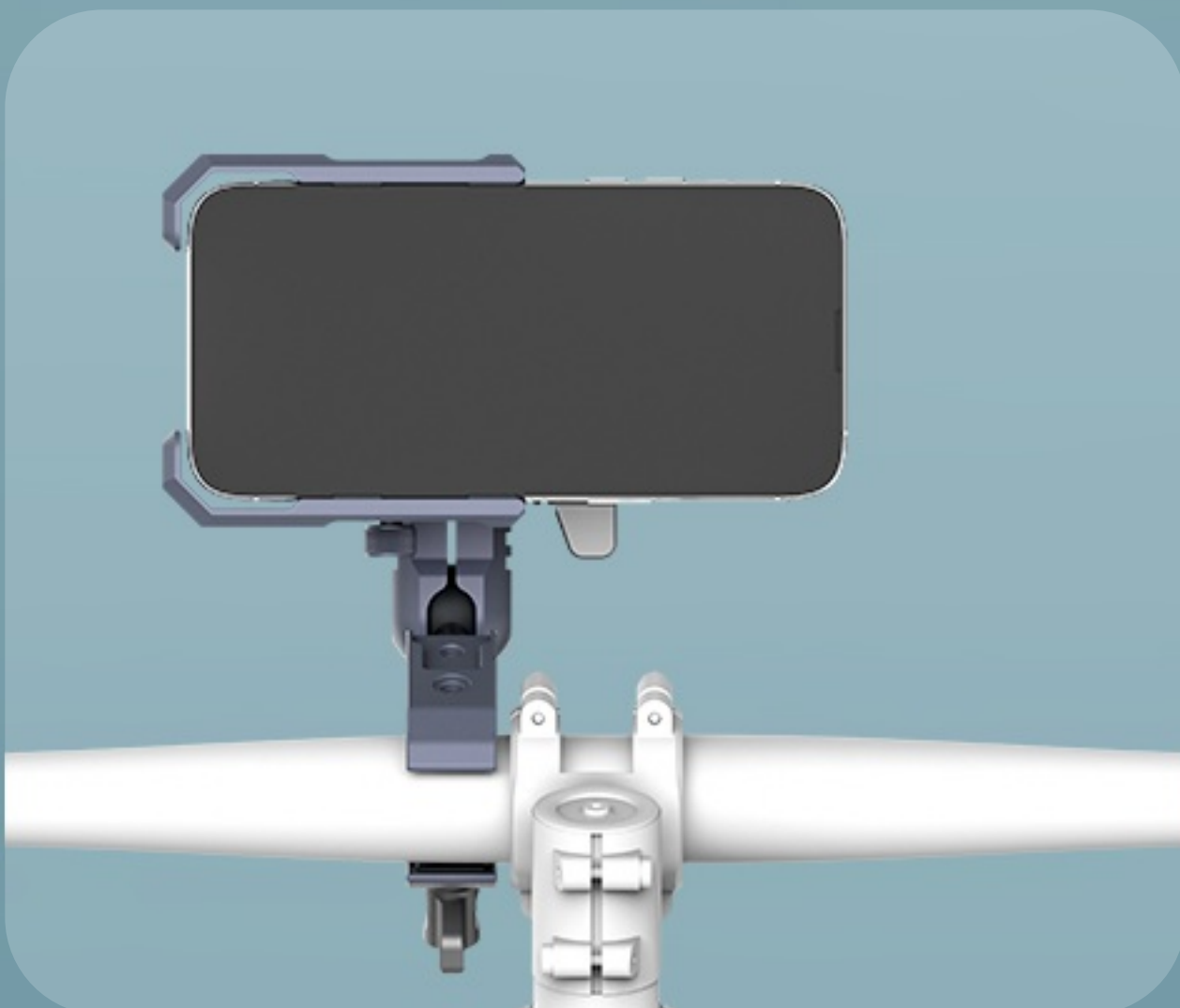

25.4 mm (1 inch)  
Standard Steel Core  
Ball Head



# Unobstructed Design

## Flexible Operation

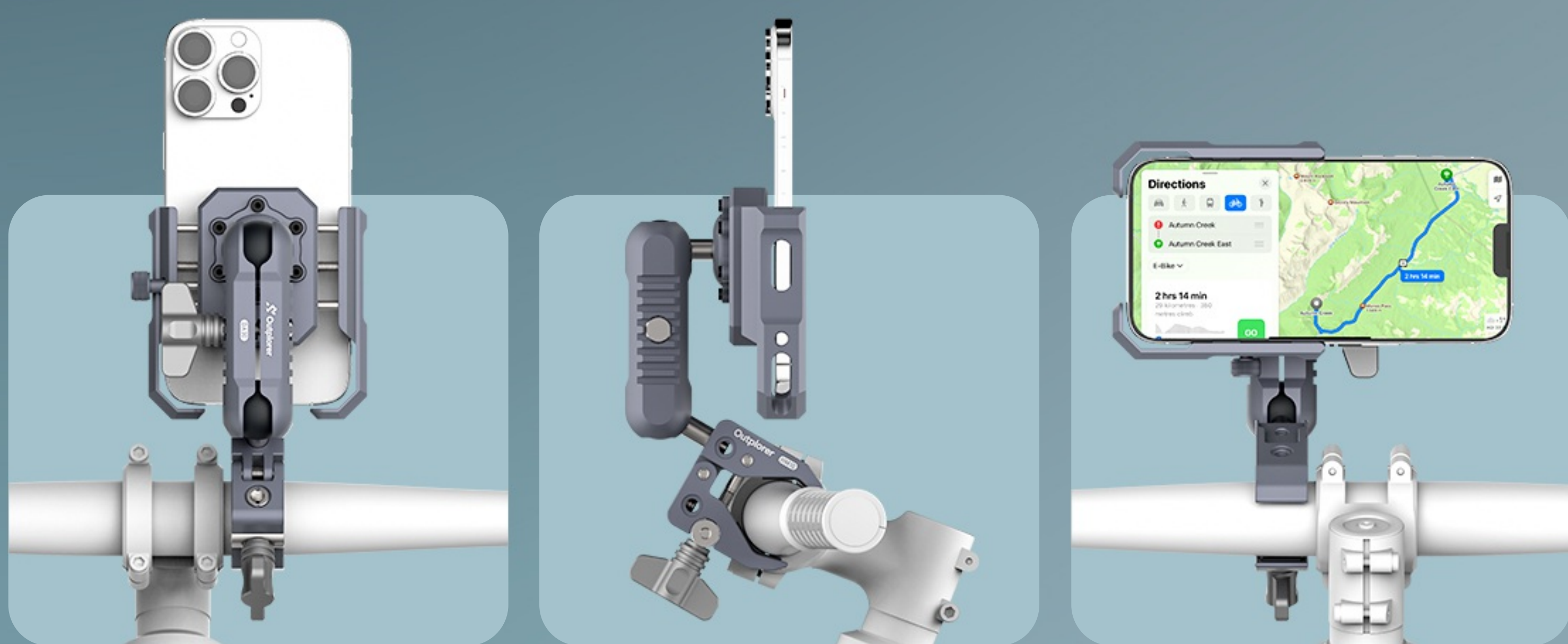

\* Handlebar Clamp Mount Requires Additional Purchase

# Anti-Theft Design

The anti-theft knob can be replaced when parked outdoors for a long time, and a dedicated wrench is required to open it.



\* Anti Theft Bolt Kit & Handlebar Clamp Mount Requires Additional Purchase



# Product Specifications

The measurements of the dimensions are manually conducted, hence a slight tolerance is inevitable. We kindly ask for your understanding.

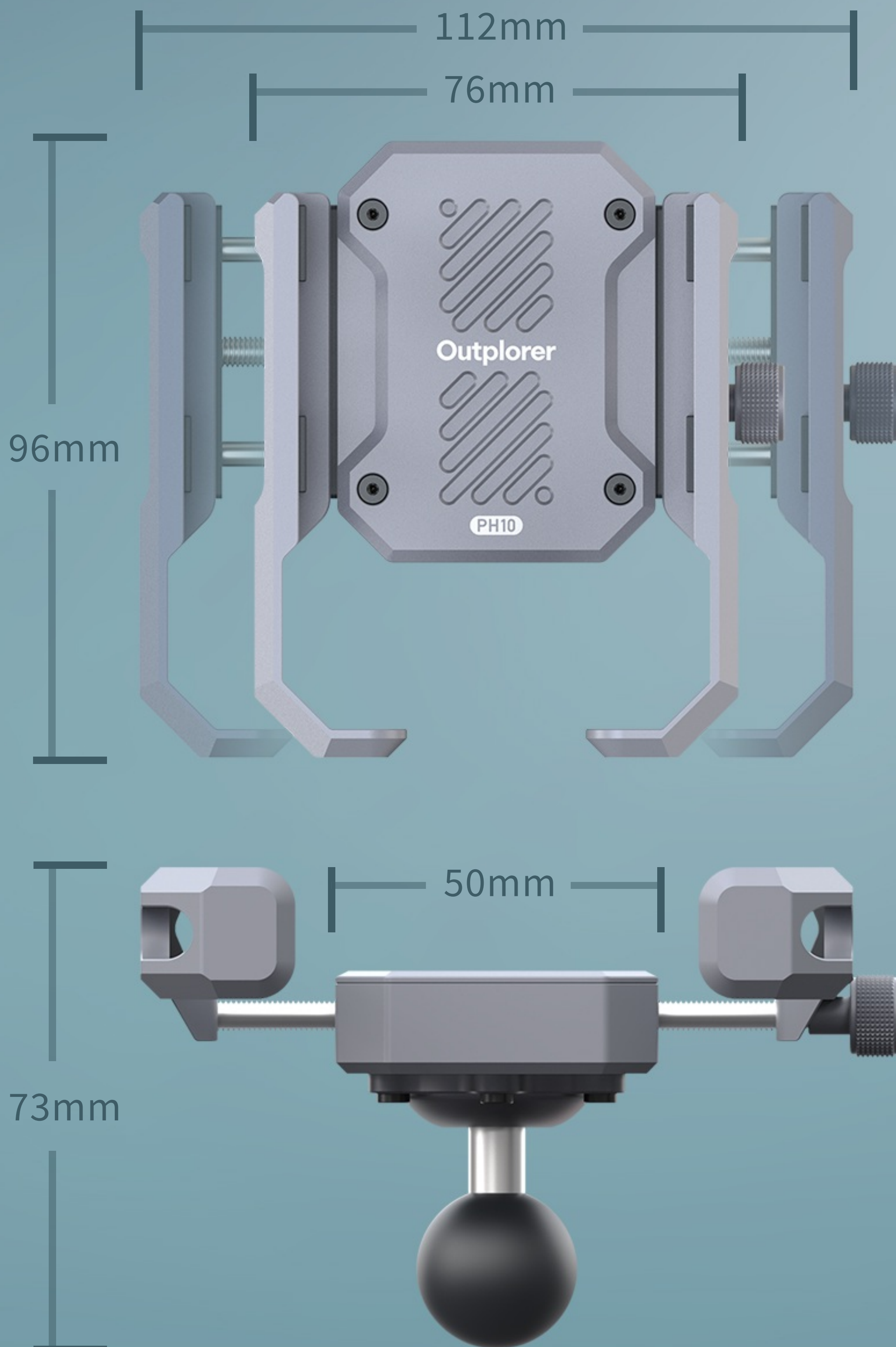

**Name**

Air Suspension Phone Mount

**Model**

PH10

**Material**

Aluminum Alloy, Zinc Alloy,  
Stainless Steel, TPR